

The Colliers logo is a blue square with the word "Colliers" in white serif font, with a horizontal bar of red, yellow, and blue stripes below it.

Colliers

A sign for Dr. Henry Wong, Dentist, featuring the name in white on a black background and "DENTIST" in white on a pink background.

DR. HENRY WONG
DENTIST

A dark, 3D-style sign for Money Mart mounted on the building facade.

Money
Mart

A small sign for TLC (Tracks Labour Corporation) with the company name and logo.

TLC
TRACKS LABOUR CORPORATION

405B Ellice Avenue, Winnipeg | MB

Retail space on Ellice Avenue **for lease**

This property is situated in downtown Winnipeg, on the corner of Ellice Avenue and Kennedy Street. Positioned along a busy thoroughfare, it features prominent pylon signage and offers ample on-site parking.

Kris Mutcher

Vice President
+1 204 926 3838
kris.mutcher@colliers.com

Accelerating success.

Property Overview

Address:	405B Ellice Avenue
Rentable Area:	887 SF
Net Rent:	\$20.00 PSF
Additional Rent:	\$13.77 PSF (2025 est.)

Management Fee:	5% Gross Rent
HVAC:	3 ton unit
Utilities:	Tenant is responsible for Gas & Hydro

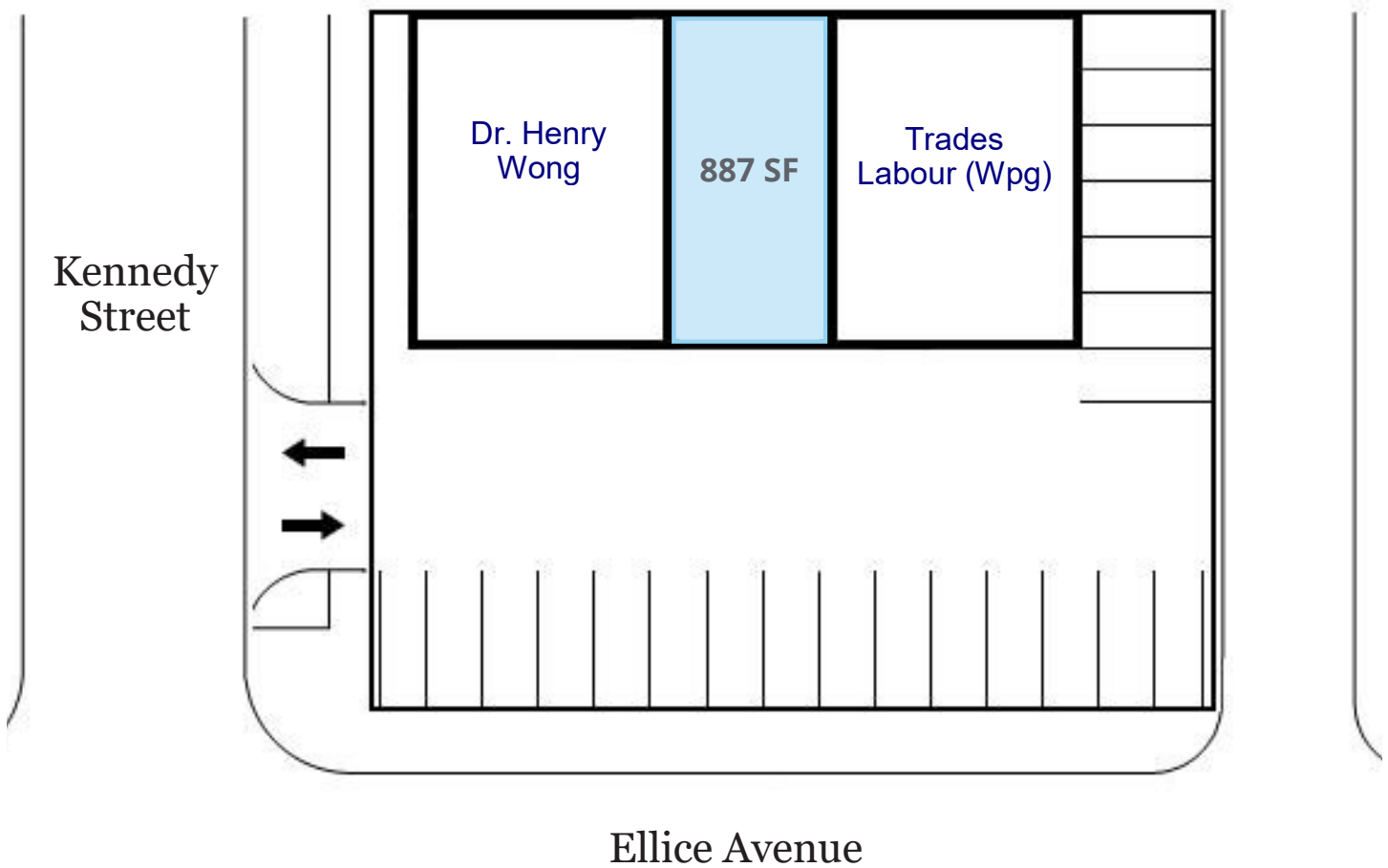

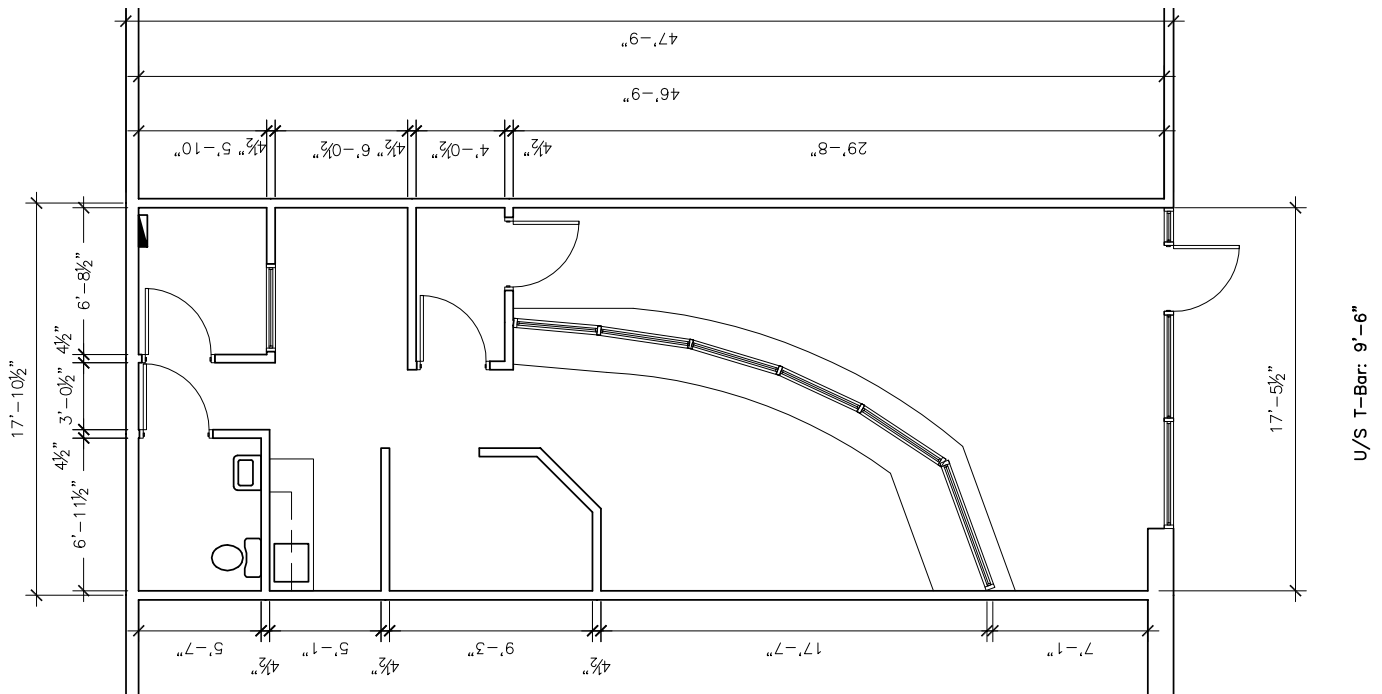

Surrounding Area

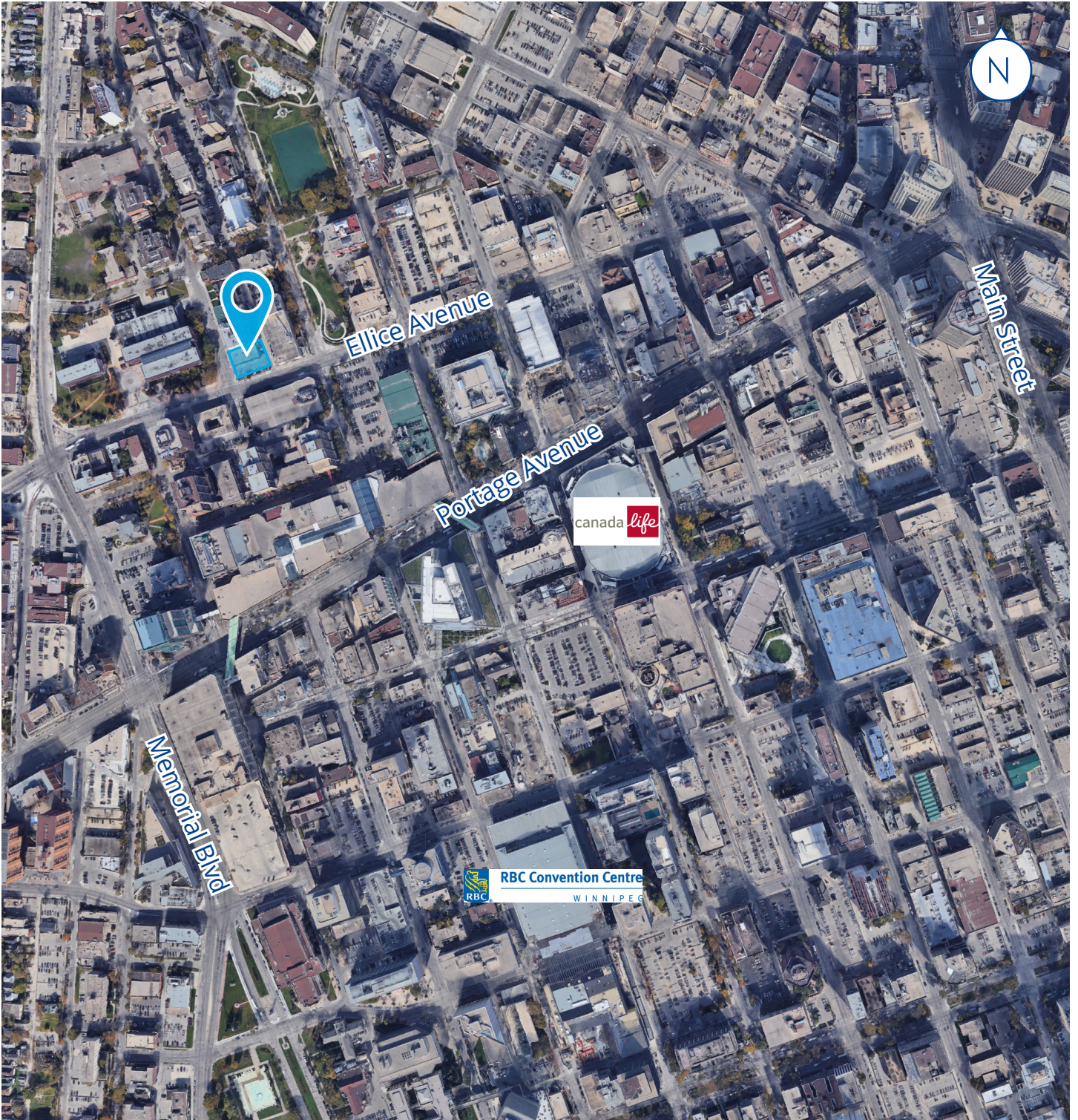



405B Ellice Avenue, Winnipeg, MB

Kris Mutcher

Vice President

+1 204 926 3838

kris.mutcher@colliers.com

This document has been prepared by Colliers for advertising and general information only. Colliers makes no guarantees, representations or warranties of any kind, expressed or implied, regarding the information including, but not limited to, warranties of content, accuracy and reliability. Any interested party should undertake their own inquiries as to the accuracy of the information. Colliers excludes unequivocally all inferred or implied terms, conditions and warranties arising out of this document and excludes all liability for loss and damages arising there from. This publication is the copyrighted property of Colliers and/or its licensor(s). Copyright © 2026. All rights reserved. This communication is not intended to cause or induce breach of an existing listing agreement. Pratt McGarry Inc. o/a Colliers International.